

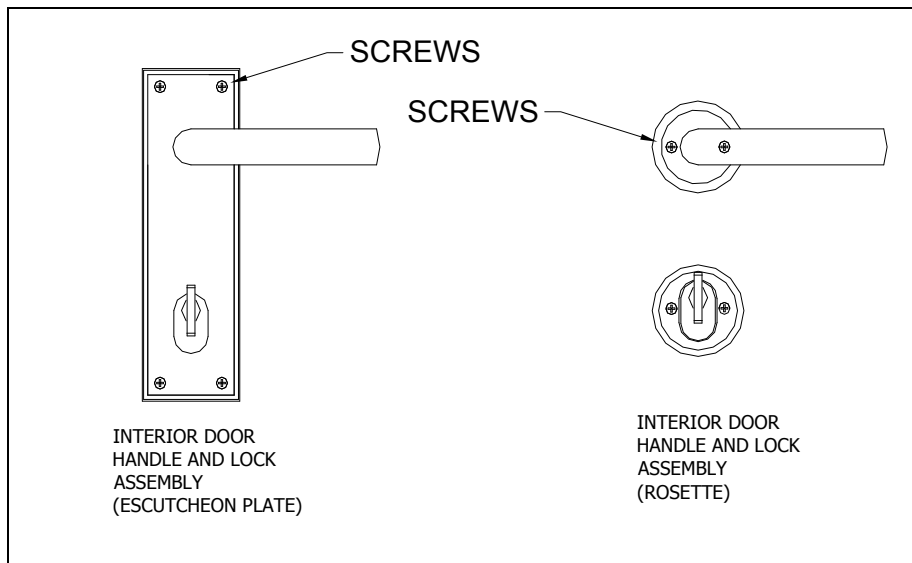

TRIOVING LOCK REMOVAL INSTRUCTIONS (Replacing Springs)

1. Start by removing either the Escutcheon Plate screws (if your lock is fit with an escutcheon plate) or the Rosettes screws (if your lock is fit with a rosette):
 - In either case, four screws will need to be removed. These screws run through the door and are fixed to blind nuts on the opposite side of the door. When the locks are assembled during production, locktite is used to prevent the screws from backing off. If you are unable to back off the screws then they may have to be drilled out and replaced with new screws when the lock is re-assembled.





DIAMOND / SEA-GLAZE

2. The next step is to Remove the Keyturn and the Thumbturn:

- Both the Keyturn and the Thumbturn are attached to the lock case by a single screw fixed through the face plate of the lock case. Remove the screws and the lock assemblies can be pulled out of the lock case.

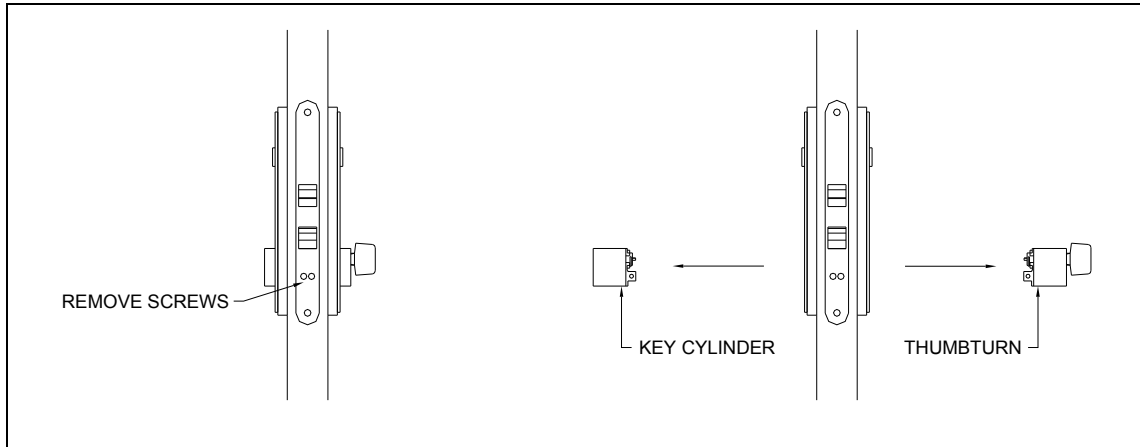

3. Proceed to remove one of the two lever handles:

- Remove the set screw on one lever handle.
- With one handle removed the other handle, complete with the shaft assembly, can be slid out of the door from the opposite side.

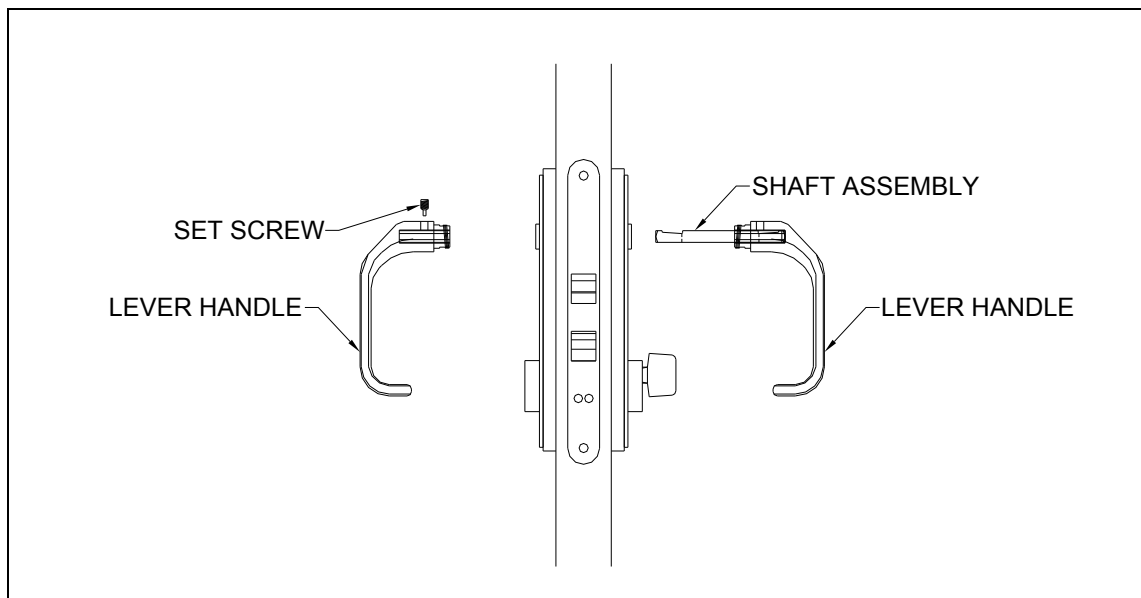



DIAMOND / SEA-GLAZE

4. Now remove the two screws that are attaching the lockcase and slide the entire lock case out of the door.

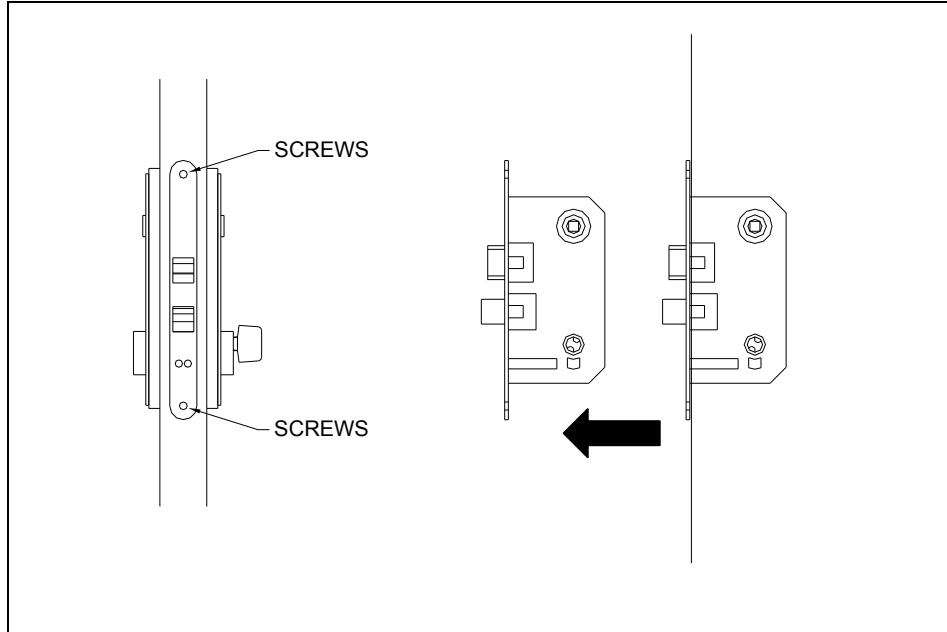

5. The lock case is fixed together with four screws. By removing the four screws the top half of the lock case can be lifted free allowing access to the internal components of the lock. Replace the damaged springs as required.

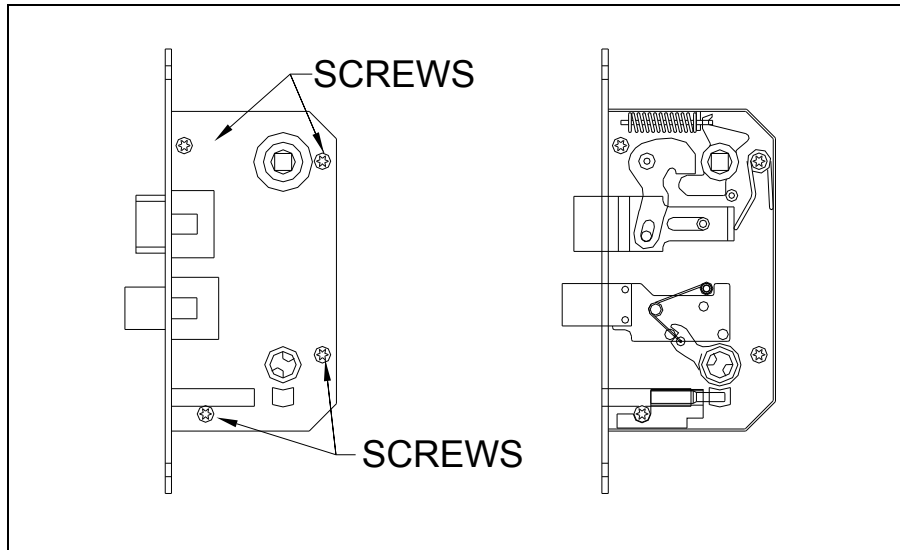

6. Re-assemble the lock.