

SECTION B-B WITH CLAMP IN INSTALLATION

ITEMS			
ID	DESCRIPTION	MATERIAL	PART NUMBER
1	MOUNTING FRAME	6063 ALUMINUM	MT - EX13953
2	GLAZING	GLASS 6mm (1/4") TO 10mm (3/8")	
3	FIXED LITE FULCRUM GLAZING	SANTOPRENE	AD - VY2572A
4	BUTYL TAPE		ADTA1/8X3/8B
5	SEALANT	SILICONE	
6	TRIM RING	6063 ALUMINUM	
7	TRIM SCREWS	S/S	
8	BEDDING COMPOUND	CUSTOMER TO SUPPLY	
9	BACKFILL	URETHANE	
10	106 MULLION	6063 ALUMINUM	MT - EX671539
11	106 FLIP OUT	6063 ALUMINUM	MT - EX785630
12	FLIP OUT GASKET	EPDM	AD - GA7808
13	HINGED LITE FULCRUM GLAZING	SANTOPRENE	AD - VY3255

STANDARD DIMENSIONS		
ID	DESCRIPTION	DIMENSION
A	FLANGE COVERAGE	20mm (7/8")
B	EXTERIOR PROTRUSION	3mm (1/8")
C	INTERIOR PROTRUSION	35mm (1 3/8")
D	SPIGOT TO CLEAR VIEW	38 mm (1 1/2")
E	FLANGE THICKNESS	3mm (1/8")
F	X - SPIGOT TO TOP CLEAR MIN	212mm (8 3/8")
G	VISUAL MULLION	60mm (2 3/8")
H	O - SPIGOT TO TOP CLEAR MIN	118mm (4 5/8")

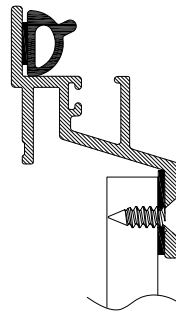

OPTIONAL BOLT-ON INSTALLATION

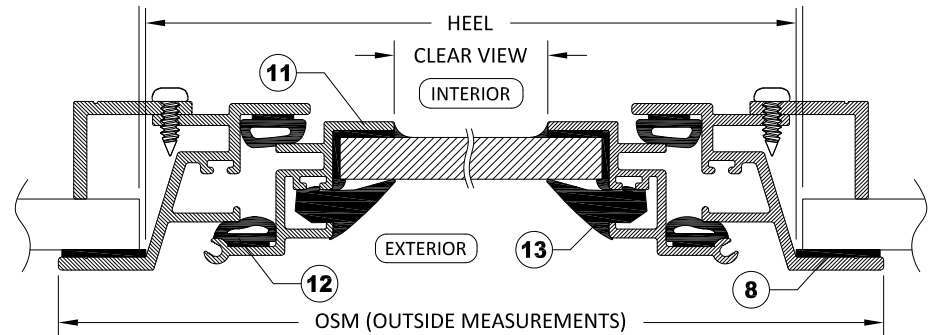

SECTION A-A WITH CLAMP IN INSTALLATION

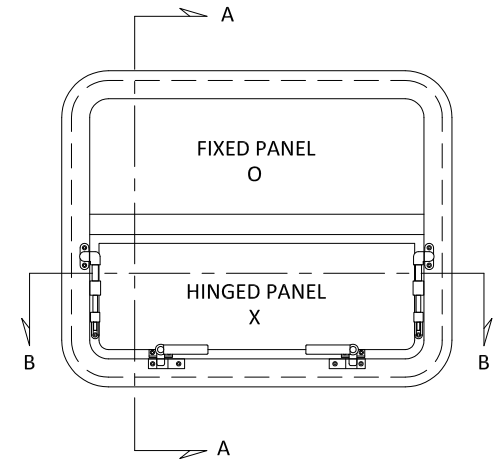

NOTES:

- GENERAL HEEL TOLERANCE +0/-1/4" OVERALL
- AVAILABLE WITH 3"(76mm) OR MITERED CORNERS
- STANDARD MOUNTING HOLES ARE 3/16" WITH #10 COUNTERSUNK ON 6" NOMINAL CENTERS
- CAM HANDLES AND ADJUSTERS NOT SHOWN IN X-SECTION
- STANDARD OF 2 CAM HANDLES & ADJUSTERS

DRAWING NUMBER

106BV

SCALE

NTS

BY

LD

DIAMOND SEA GLAZE MANUFACTURING LTD.  
26995 GLOUCESTER WAY, LANGLEY B.C.  
CANADA V4W 3Y3  
TOLL FREE: 1-800-770-0455  
PHONE: 604-607-0091  
FAX: 604-607-0092



**Diamond Sea Glaze**

*Crystal Clear. Rock Solid.*

ITEM NAME

106BV

REVISION

0

ITEM DESCRIPTION

COMMERCIAL DUTY WINDOWS

ALL DRAWINGS AND ANY ASSOCIATED INFORMATION HEREON CONTAIN PROPRIETARY AND/OR CONFIDENTIAL INFORMATION, AND SHALL NOT BE REPRODUCED, DISCLOSED OR SUBMITTED TO ANY THIRD PARTY WITHOUT PRIOR CONSENT FROM DIAMOND SEA GLAZE MANUFACTURING LTD.